

УДК 532.545

THE MIXING AND SEGREGATION EFFECTS DURING SHEAR DEFORMATION OF COHESIONLESS PARTICULATE SOLIDS

V.N. Dolgunin¹, V.Ya. Borschev², R.A. Shubin²

*Departaments: «Technological Equipment and Food Technologies» (1),
«Machines and Devices of Chemical Manufactures» (2), TSTU;
borschev@yandex.ru*

Represented by a Member of the Editorial Board Professor V.I. Konovalov

Key words and phrases: the mixing and segregation kinetics; segregation coefficient; shear cell; shear deformation.

Abstract: The mixing and segregation kinetics in the course of shear flow of particulate solids at low shear rates is studied analytically and experimentally. Only one experimental constant (segregation coefficient) is used to forecast the segregation and mixing dynamics of nonelastic cohesionless rough spherical particles.

Introduction

In our previous paper [1] we have suggested the experimental unit and method of segregation and mixing exploration during shear deformation of particulate solids. Then a mathematical description of the mixing effect during shear flow of particulate solids was carried out. The kinetic parameters of the mixing flux were determined on the basis of the analysis of chaotic transversal movements of spherical nonelastic cohesionless particles (transversal mass transfer) in a restricted environment. These chaotic movements are formally analogical to the quasidiffusional mixing of particles.

That is why the mixing flux of particles is expressed as the quasidiffusional mixing flux in the transversal direction

$$j_m = -D_{\text{dif}} \rho_b (\partial c / \partial y) = -0,5s \rho_b u_t (\partial c / \partial y), \quad (1)$$

where D_{dif} is the coefficient of quasidiffusional mixing; c is the concentration of test particles; s is the mean distance between particles ρ_b is the bulk density of particulate solids. The mean relative transversal velocity between particles of neighbouring flow layers is calculated on the basis of the analysis of chaotic transversal movements of spherical nonelastic cohesionless particles (transversal mass transfer) in a restricted environment (Fig. 1)

$$u_t = (du/dy) b d \sin((\pi/4)(d+s)/d), \quad (2)$$

where d is the mean particle diameter; $b = (\pi/(6(1-\varepsilon)))^{0.33}$ is the geometrical parameter; b_0 is the geometrical parameter b , calculated at $\varepsilon = \varepsilon_0 = 0,2595$, ε is the fraction of void volume.

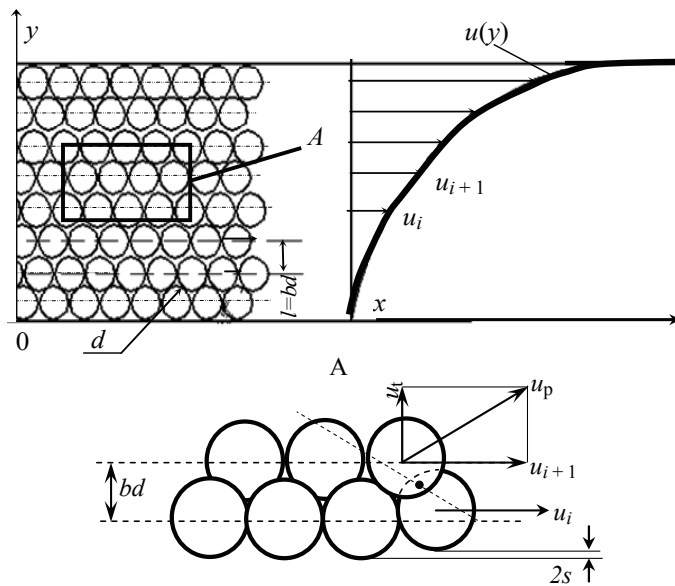

Fig. 1. Schematic of structural and kinematical parameters determination

However, the real particulate solids is not uniform in complex of physical and mechanical properties and then the chaotic movements are accompanied by systematic displacements of particles because of segregation effects.

Although segregation has long been known and has been used over centuries in human activities, e.g. in grain and cereal cleaning, gold dust mining, etc., the scientific cognition of this physical phenomenon is still in its infancy [2]. This is because the segregation phenomenon, albeit simple in appearance, has extremely complex and diverse physical mechanisms.

In the context of the above, it is very important to perform investigations to reveal mechanisms and kinetic laws of segregation for the most general and practically important cases of flow of granular media, e.g., shear deformation flows.

The segregation flux j_s is determined on the basis of the mechanism of hydromechanical segregation [3], which developed here in terms of «slow» shear flow of particulate solids when prolonged interparticle contacts take place.

Taking into account the fact that the segregation kinetics at low shear rates doesn't depend practically on the shear stress we formulated the segregation driving force as the relative excess moment of forces acting on a test particle in a nonuniform medium

$$\Delta M_r = (M - M_0)/M_0, \quad (3)$$

where $M = M_g + M_f$ is the sum moment of gravity M_g , friction M_f forces acting on a test particle of the mixture, M_0 is analogous moment acting on an average particle of the mixture. These moments are calculated analytically.

Taking into account that the segregation intensity is proportional to the shear rate [4] we expressed the segregation flux in the following way

$$j_s = K_s c \rho_b u_r \Delta M_r = K_s c \rho_b b (du/dy) \Delta M_r, \quad (4)$$

where K_s is the segregation coefficient, u_r is the mean relative shear velocity between interacting particles.

Method of segregation coefficient determination in according with (4) the segregation coefficient acquires the physical sense of the relation between transversal and tangent velocities of test particles and ΔM_r parameter is adequate to the separation factor which determines the inclination of mixture particles to segregation.

Then the segregation coefficient is determined as follows

$$K = u_t / (\Delta M_r b d (du / dy)), \quad (5)$$

where u_t is the mean transversal velocity of a single test particle determined experimentally in the conveyor shear cell [1] using uniform bulk particles.

The experimental results of a segregation coefficient investigation are shown on Figs. 2 and 3.

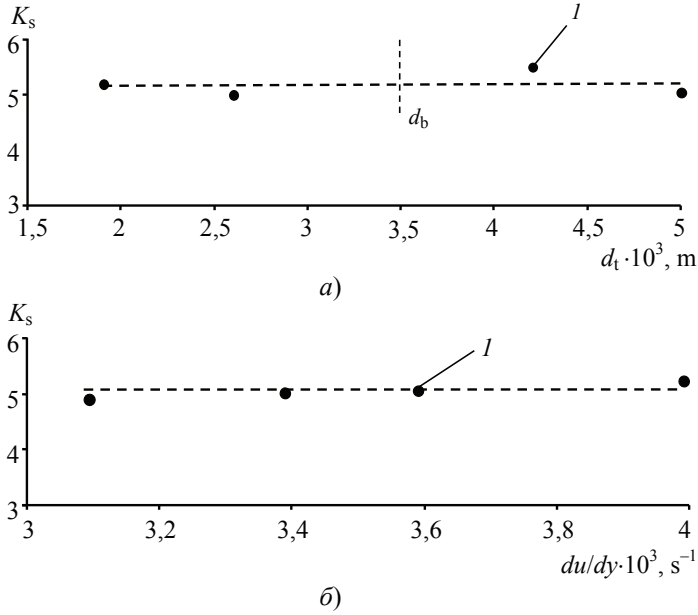

Fig. 2. Segregation coefficient dependence on the test particle diameter (a) and the shear rate (b) for glass beads ($d_b = 3.5 \cdot 10^{-3} \text{ m}$)

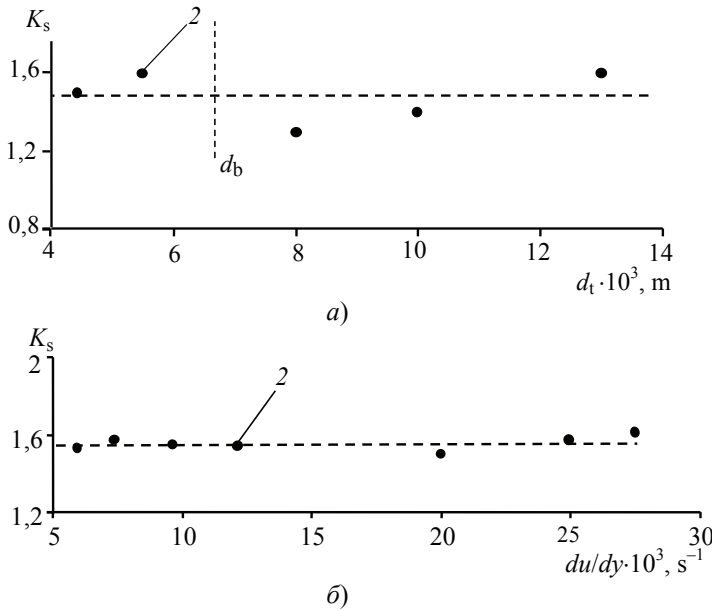

Fig. 3. Segregation coefficient dependence on the test particle diameter (a) and the shear rate (b) for ceramic granules ($d_b = 6.6 \cdot 10^{-3} \text{ m}$)

Mathematical simulations of segregation and mixing effects

The mathematical description of the joint segregation and mixing effect in the course of shear deformation of particulate solids is based on the general mass transfer equation, which was adapted here to the steady two-dimensional shear flow as follows

$$\partial c \rho_b / \partial \tau = -\partial (u c \rho_b) / \partial x + \partial (j_m - j_s) / \partial y, \quad (6)$$

where u is the mean particle velocity towards shear direction x (x, y). Cartesian coordinates, τ is the time.

The boundary conditions for Eq. (6) are formulated in the absence of transverse material flows at the upper and lower boundaries

$$\partial (j_m) / \partial y = \partial (j_s) / \partial y = 0, \text{ when } y = 0, h, \quad (7)$$

where h is the bed height. The initial condition has the form

$$\begin{cases} c(0 < x \leq 0.04, y, 0) = 1; \\ c(x > 0.04, y, 0) = 0. \end{cases} \quad (8)$$

The kinetic parameters D_{dif} and ΔM_r of this equation are calculated by means of Eqs. (1)–(3). The kinetic constant K_s is found experimentally (Figs. 2 and 3). The flow characteristics, such as $u(y)$ and $\varepsilon(y)$, were gotten experimentally by means of the method using the conveyor shear cell [1], e.g. see Fig. 4.

Eq. (6) is integrated numerically. The comparison of the calculated and experimental results shown on Figs. 5 and 6 reveals their adequacy. The standard deviation between the named results of segregation and mixing dynamics modeling is 5...6 percentage.

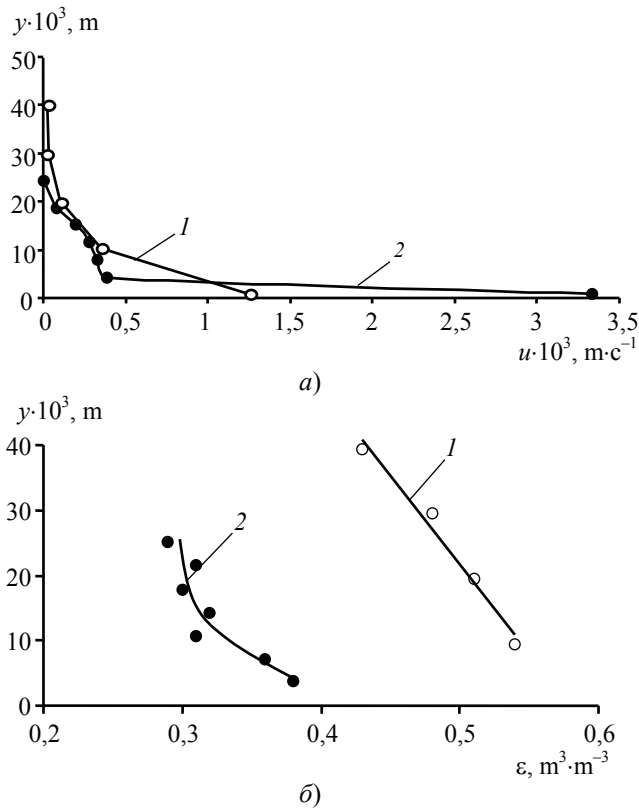
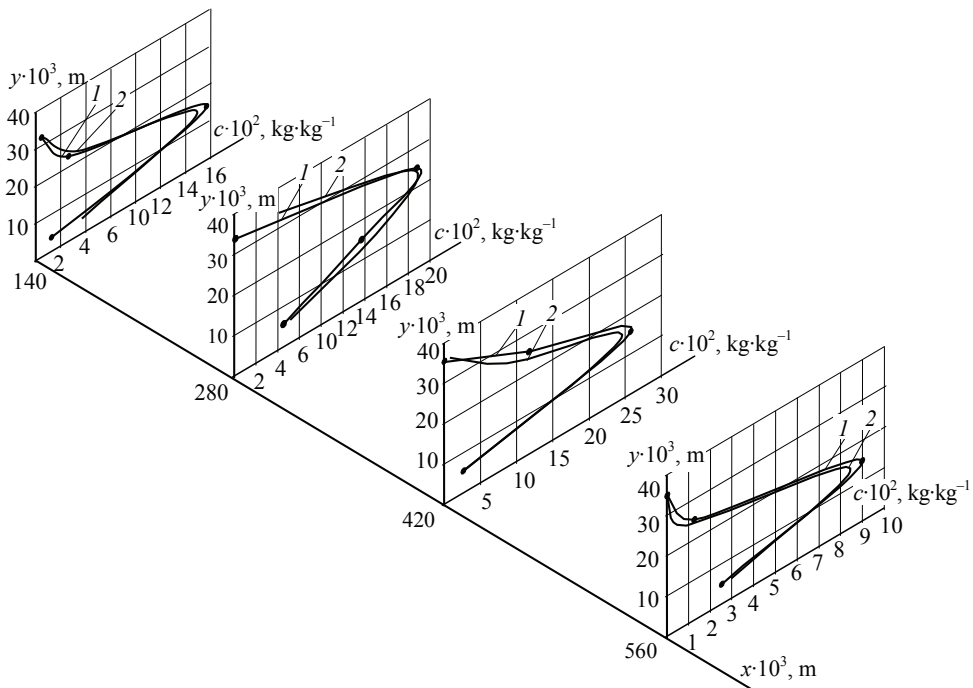
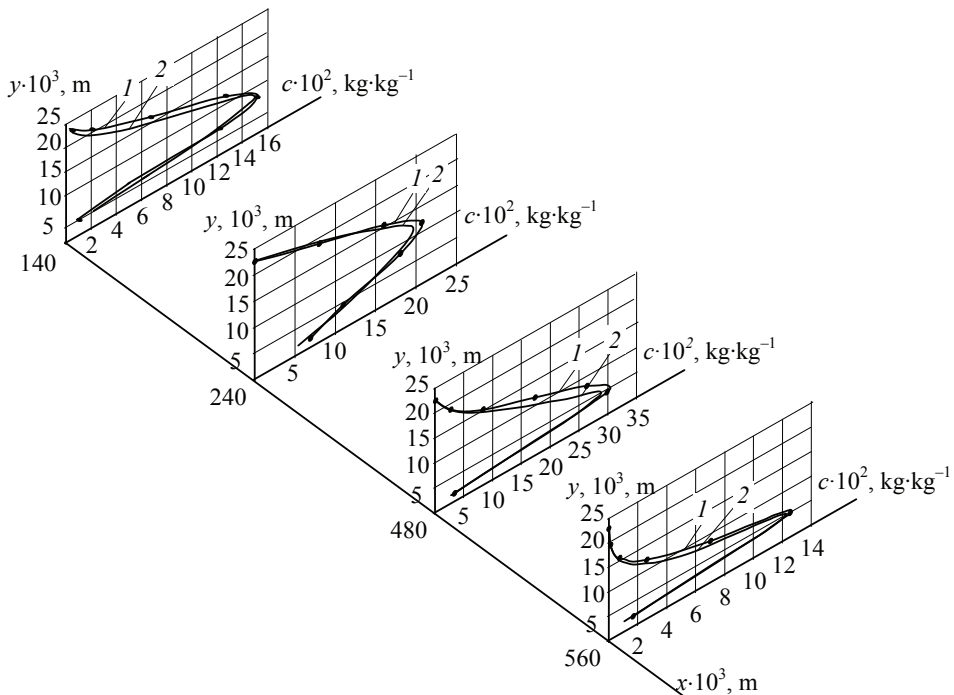

Fig. 4. Velocity (a) and the fraction of void volume (b) profiles during shear deformation of ceramic granules (1) and glass beads (2) in the conveyor shear cell



**Fig. 5. Segregation dynamics during shear deformation of ceramic granules ($d_t = 4.4 \cdot 10^{-3}$ m, $d_b = 6.6 \cdot 10^{-3}$ m) in the conveyor shear cell at the mean shear rate 0.475 s^{-1} :
1 – experimental; 2 – calculated**



**Fig. 6. Segregation dynamics during shear deformation of glass beads ($d_t = 3.1 \cdot 10^{-3}$ m, $d_b = 3.5 \cdot 10^{-3}$ m) in the conveyor shear cell at the mean shear rate 0.76 s^{-1} :
1 – experimental; 2 – calculated**

Conclusions

The suggested mathematical simulation has rather high predictive power, which is confirmed by the results of studying the segregation kinetics and dynamics. Furthermore, the study showed that not only can the mathematical model of the shear flow separation mechanism be used to describe the separation of a mixture of particles, but also this model can be applied to predict the velocities of both small and large single spherical cohesionless particles during shear deformation using a single kinetic coefficient.

References

1. Borshchov, V.Ya. The conveyor shear cell for determination of particle tendency to segregation and mixing during shear flow of particulate solids / V.Ya. Borshchov, V.N. Dolgunin, R.A. Shubin // Trans. of the Tambov State Technical University. – 2006. – Vol. 12, № 3A. – P. 695–699.
2. Savage, S.B. Interparticle Percolation and Segregation in Granular Materials : A Review, in Developments in Engineering Mechanics, Selvadurai, A.P.S., Ed., Amsterdam : Elsevier Science, 1987. – P. 347–363.
3. Dolgunin, V. Segregation modeling of particle rapid gravity flow / V. Dolgunin, A. Ukolov // Powder Technology. – 1995. – № 83. – P. 95–103.
4. Bridgwater, J. Interparticle Percolation: Equipment development and Mean Percolation Velocities / J. Bridgwater, M.H. Cooke, A.M. Scott // Trans. I Chem. E. – 1978. – Vol. 56. – P. 157–167.

Эффекты перемешивания и сегрегации при сдвиговой деформации несвязных зернистых материалов

В.Н. Долгунин¹, В.Я. Борщев², Р.А. Шубин²

Кафедры: «Технологическое оборудование и пищевые технологии» (1), «Машины и аппараты химических производств» (2), ГОУ ВПО «ТГТУ»;
borschev@yandex.ru

Ключевые слова и фразы: кинетика сегрегации и смешения; коэффициент сегрегации; сдвиговая деформация; сдвиговая ячейка.

Аннотация: Проведено аналитическое и экспериментальное исследование кинетики сегрегации и смешения в процессе сдвигового течения зернистых материалов при низких скоростях сдвига. Прогнозирование динамики сегрегации и смешения несвязных неэластичных сферических частиц осуществляется с использованием единственной экспериментальной константы – коэффициента сегрегации.

Effekte der Segregation und der Mischung bei der Schieberdeformation von den unzusammenhängenden Kornstoffen

Zusammenfassung: Es ist die analytische und experimentelle Untersuchung der Kinetik der Segregation und der Mischung im Prozess des Schieberlaufes der Kornstoffe bei den niedrigen Geschwindigkeiten der Verschiebung durchgeführt. Die

Prognostizierung der Dynamik der Segregation und der Mischung der unzusammenhängenden unelastischen sphärischen Teilchen wird mit der Benutzung der einzigen Experimentalkonstante – des Koeffizienten der Segregation verwirklicht.

Les effets du mélangeage et de la ségrégation durant la déformation de cohésion des matières en grains non liées

Résumé: Est réalisée une étude analytique et expérimentale de la cinétique ségrégation et du mélangeage durant l'écoulement de cohésion des matières avec des basses vitesses de la cohésion. La prévision de la dynamique ségrégation et du mélangeage des particules inélastiques non liées est réalisée avec l'utilisation d'une seule constante expérimentale – coefficient de la ségrégation.

Авторы: *Долгунин Виктор Николаевич* – доктор технических наук, профессор кафедры «Технологическое оборудование и пищевые технологии»; *Борщев Вячеслав Яковлевич* – доктор технических наук, профессор кафедры «Машины и аппараты химических производств»; *Шубин Роман Александрович* – кандидат технических наук, старший преподаватель кафедры «Машины и аппараты химических производств», ГОУ ВПО «ТГТУ».

Рецензент: *Гатапова Наталия Цибиковна* – доктор технических наук, профессор, заведующая кафедрой «Химическая инженерия», ГОУ ВПО «ТГТУ».
